

FRONT  
PANEL

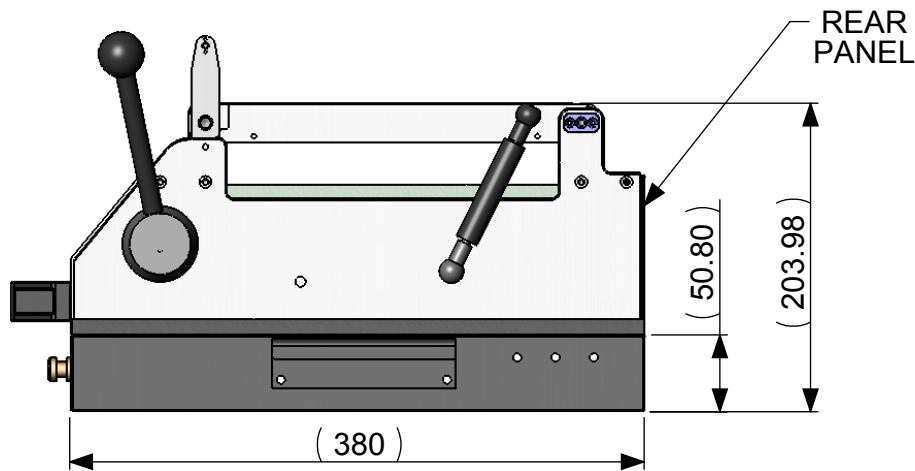

REAR  
PANEL

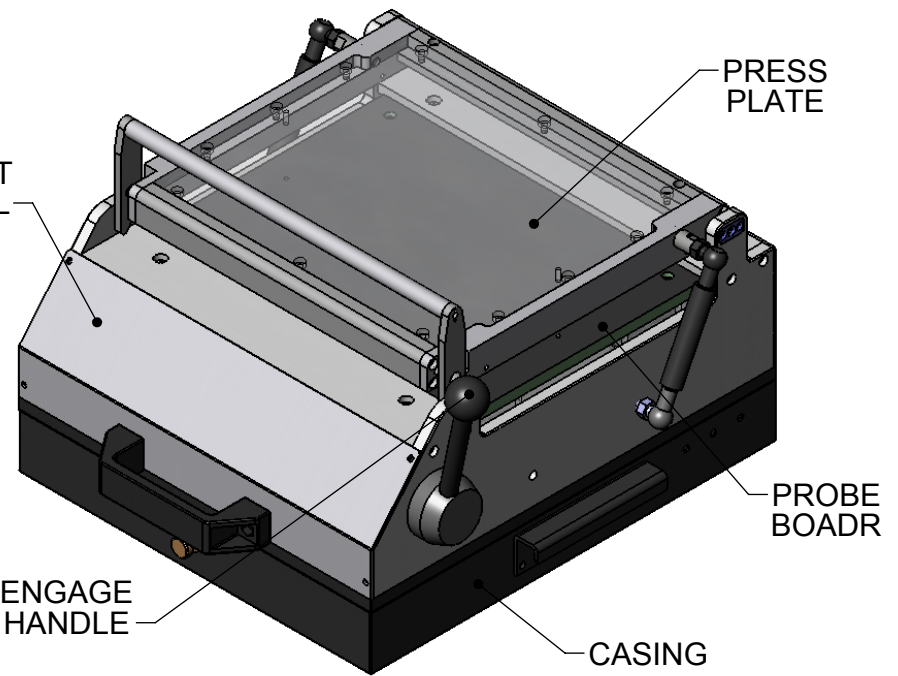
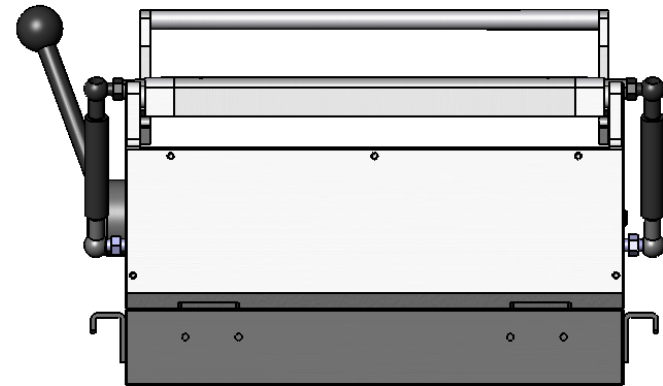

## Model : PM1

### Specification : Manual Engagement

Tested PCBA size : maximize 240x220 (mm)  
 Probe Board Material : 10mm Thk Antistatic G10(black colour)  
 Press Plate Material : 10mm Thk Antistic Acrylic Clear  
 Probe Board Travel : 10.0 mm  
 Press Finger Height : 35 mm  
 Load pogo pin quantity : less than 400 pcs .  
 Casing height : 50.8 mm ; 101.6 mm  
 Casing Material : Aluminium 6061; E.G plate  
 Tester Afford Temperature Range: -40° ~ 90°  
 Tester Surface Treatment : Powder coating .  
 Tester Weight : 12 ~15 kg

## PENG CHENG AUTOTECH PTE LTD

Singapore

Contact No: 65- 98387358

Contact Person: Mr. Fan

Email : pengcheng@pengcheng.com.sg